

ARKETIPO / INDOOR

DIVANO BACK PACK

designed by Giuseppe Vigano' 2022



STRUTTURA (sedute e schienali): legno.

IMBOTTITURA SEDUTA: poliuretano espanso a quote differenziate (D30+Memory foam) rivestito con Tomana 230 gr.

IMBOTTITURA SCHIENALE: poliuretano espanso a quote differenziate (D30+D25) rivestito con Tomana 230 gr.

IMBOTTITURA RULLO: poliuretano espanso rivestito con vellutino accoppiato 180 gr.

IMBOTTITURA CUSCINO SCHIENALE (7110862):gabardina di cotone 100% antipiuma riempita con piuma d'oca e fibra di poliestere.

IMBOTTITURA CUSCINO SCHIENALE (7110863): Tessuto esterno in gabardina 30/20 bianco (100% cotone).
Imbottitura 100% piuma d'oca, dima interna in poliuretano espanso (T18S).

ALTEZZA SEDUTA: 37 cm.

ALTEZZA SCHIENALE: 66 cm.

PIEDI: Pouf: plastica, h. 3 cm - Schienale: metallo verniciato marrone micaceo, h.1,5 cm.

TAVOLINO: legno impiallacciato finitura eucalipto o zebrano.

**Composizione 'G' (seduta A3 Schienale S2
+ seduta B1 + seduta C1 + n°2
schienali S2 + Schienale S3 +
n.3 cuscini schienale + n°2
rulli + tavolino)**

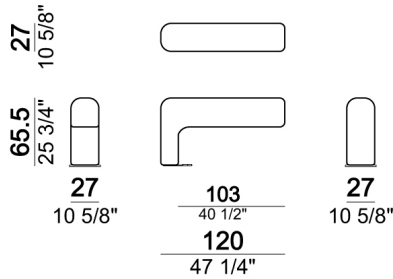
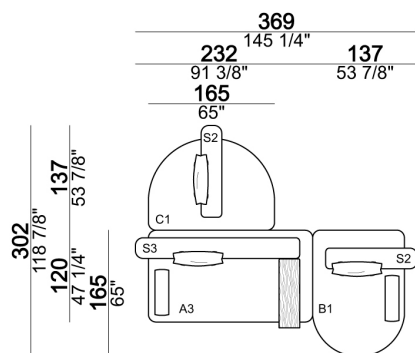

**Composizione 'F' (n°2 sedute
C1 + schienale S2 + n.2
cuscini schienale + rullo)**

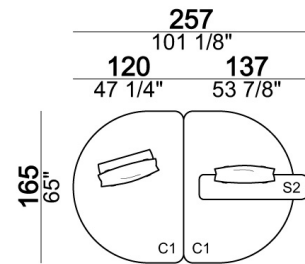

Schienale S3

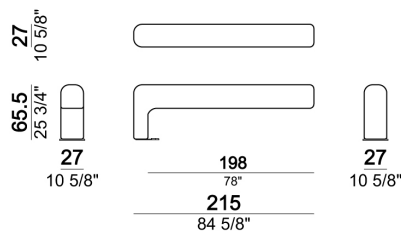

Tavolino

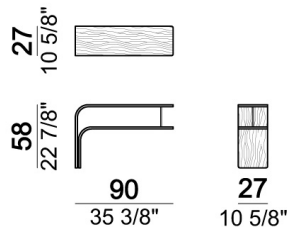

**Composizione 'E' (seduta A3
+ schienale S3 + n.2 cuscini
schienale + rullo)**

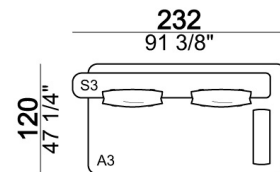

Cuscino Schienale

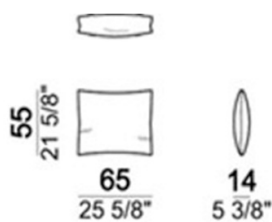

**Composizione 'B' (seduta B1 Rullo per bracciolo o
+ seduta C1 + n.2 schienali S2 supporto per cuscino
+ rullo + n.2 cuscini schienale
+ tavolino)**

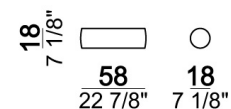
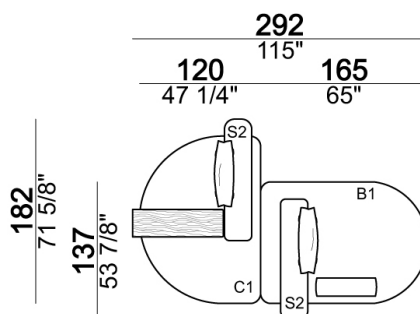

**Composizione 'L' (seduta A3 Cuscino Schienale
+ seduta B1 + 1 schienale S2 +
1 Schienale S3 + 2 cuscini
schienale 7110862 + 1 cuscino
schienale 7110863 + rullo +**

Seduta A3

tavolino)

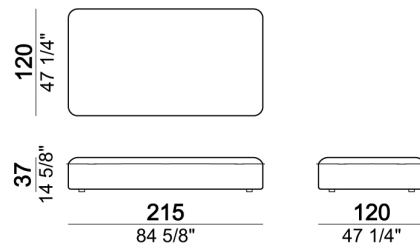
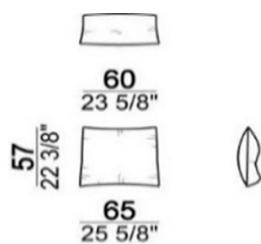
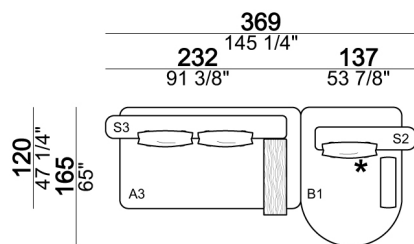

Composizione 'D' (seduta A2 + seduta B1 + n.2 schienali S2 + n.2 cuscini schienale + rullo)

Composizione 'C' (seduta A2 + seduta B1 + seduta C1 + n.2 schienali S2 + n.1 schienale S1 + rullo + n.3 cuscini schienale + tavolino)

Composizione 'A' (seduta A3 + n.2 schienali S2 + n.2 cuscini schienali + tavolino)

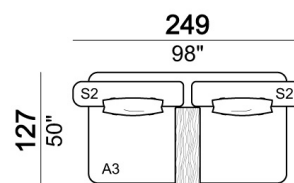
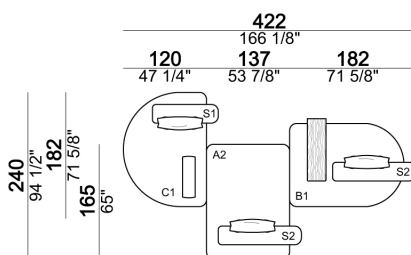
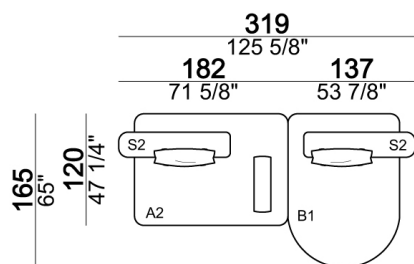

Composizione 'H' (n°2 sedute Seduta A1 A2 + n°2 sedute B1 + n°2 schienali S2 + Schienale S3 + n.5 cuscini schienale + rullo)

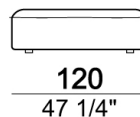
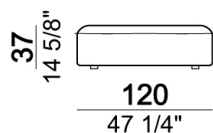
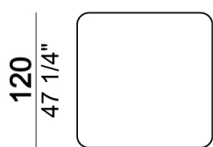
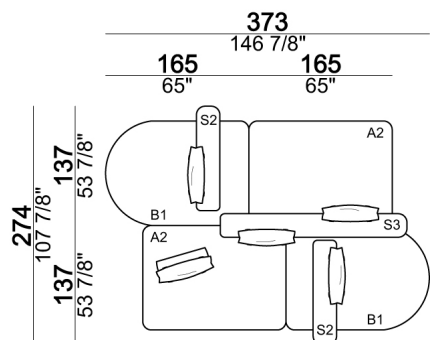

Seduta C1

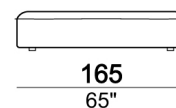
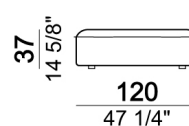
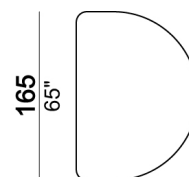

Seduta B1

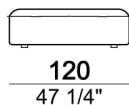
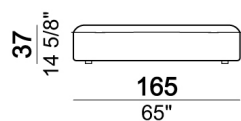

Schienale S1

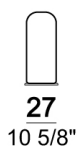
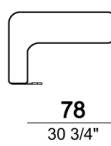
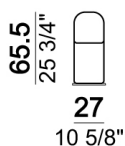

Seduta A2

